

STANDARD MATERIALS AND CONSTRUCTION

- FRAME:** 18-GA. galvanized steel, channel or flanged type.
- BLADE:** 18-GA. galvanized steel. Blades approximately 2½" on centers.
- SCREEN:** (When indicated)
½" sq. mesh, 19-GA. galvanized steel (.041").
- CONSTRUCTION:** Riveted and/or welded for maximum service.

OPTIONS

- Frames and Blades of other gauges
- Other materials - Stainless steel, Copper, Aluminum, etc.
- Finishes - Enamels, Epoxies, etc.
- Screens - Insect screen ⅛" aluminum mesh,
-or- ½" flattened aluminum, .051",
-or- ¼" sq. mesh, 18-GA galvanized steel, .047",
-or- ½" sq. mesh, 18-GA stainless steel, .047",
Others available.

NOTES

1. Nominal deductions will be made to the opening size given.
2. Approximate shipping weight is 5.5 lbs./sq.ft.

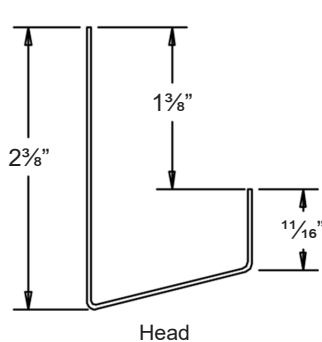
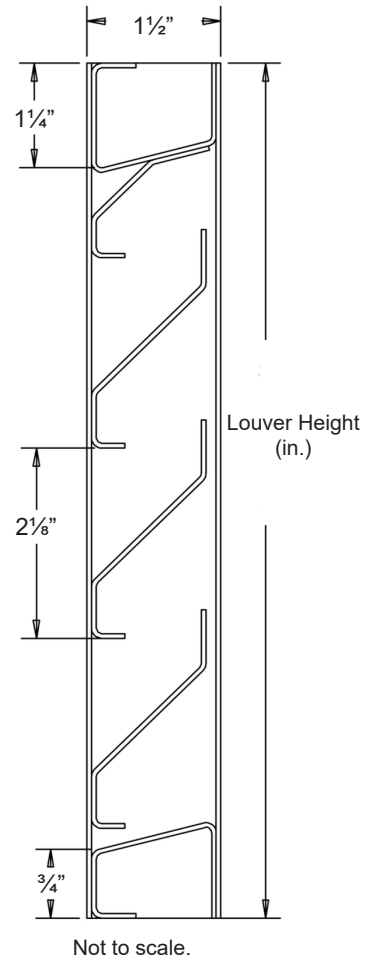
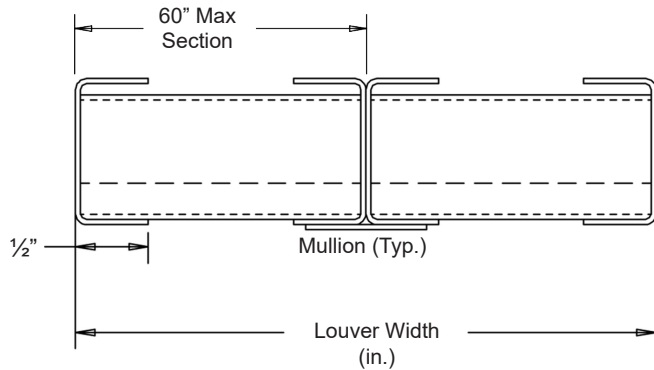

Flange Frame Available

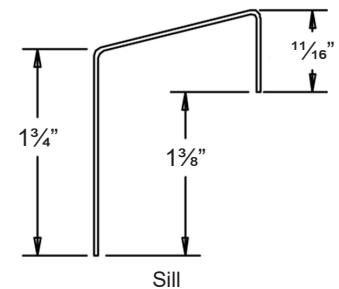
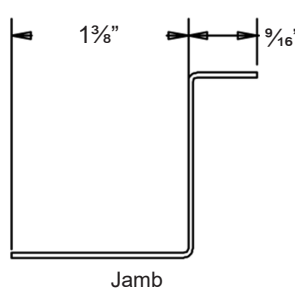

Item #	Qty	Width	Height	Width	Height	Mullion	Type	Location	Union Made
		Opening Size		Louver Size			Screens		
Arch. / Eng. :						EDR:	ECN:	Job:	
Contractor:									
Project:						Date:	DWN:	DWG:	

